

Lexus Shifter TCU Mag V 20.0

File Name: Lexus Shifter TCU Mag V 20.0

Harness Required: G14 & G06

Last Changed: 06/05/2011

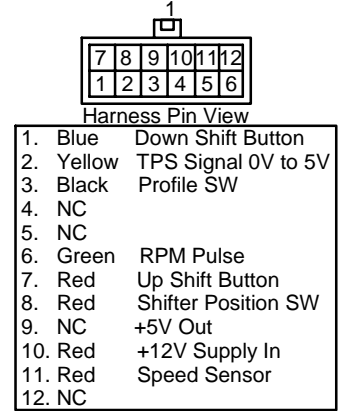
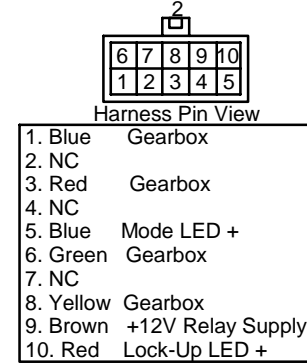
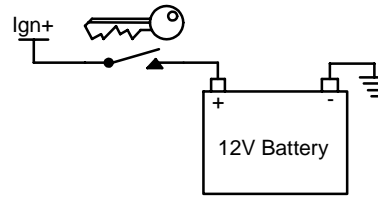

NC - Not Connected
 Ign+ Ignition Power
 Earth
Terminal Connections with the same name are tied together

Led's Functions
 Yellow - Power
 Green - Diagnostic

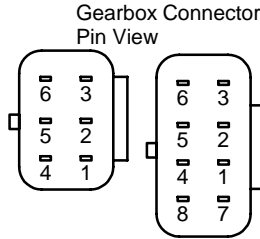
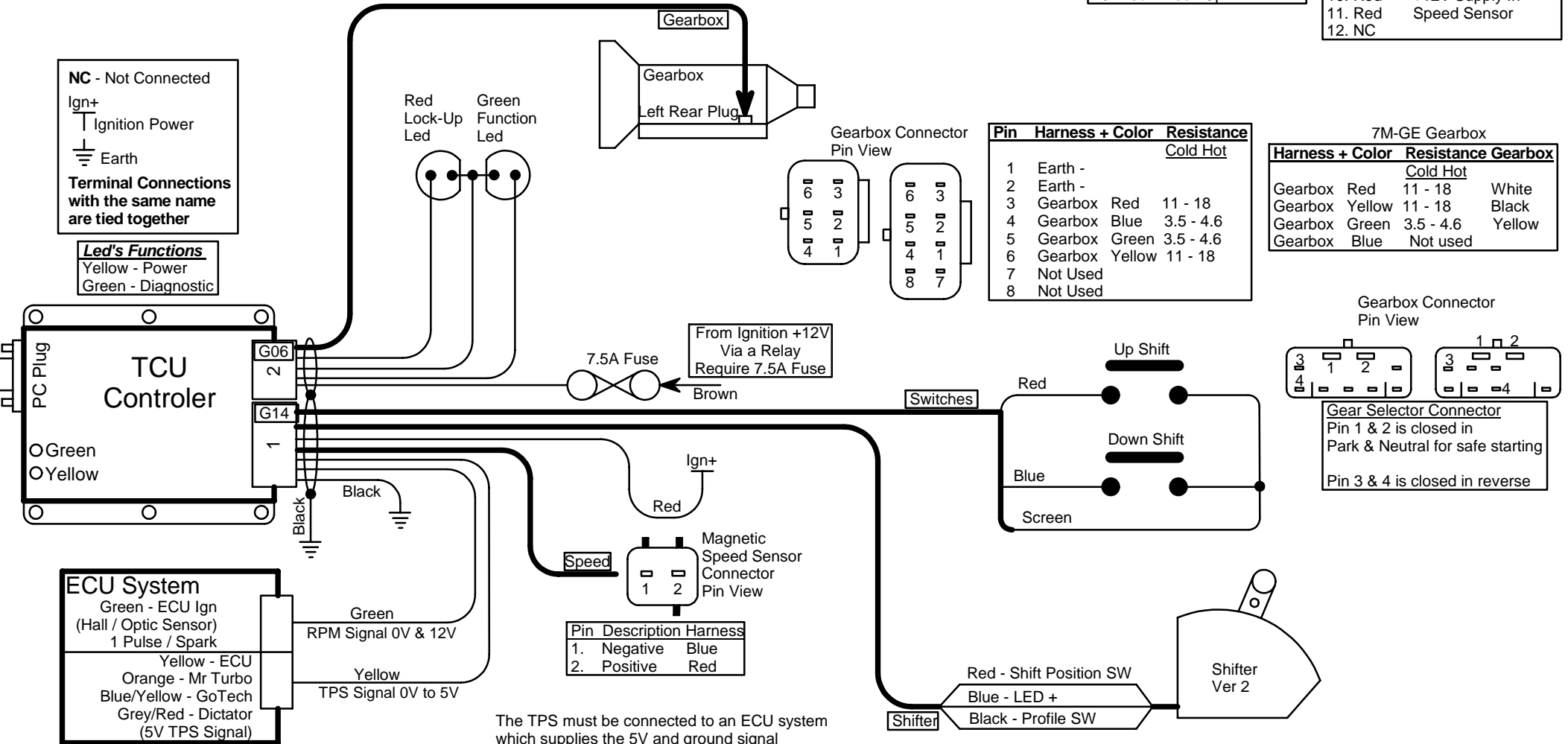

Pin	Harness + Color	Resistance	
		Cold	Hot
1	Earth -		
2	Earth -		
3	Gearbox Red	11 - 18	
4	Gearbox Blue	3.5 - 4.6	
5	Gearbox Green	3.5 - 4.6	
6	Gearbox Yellow	11 - 18	
7	Not Used		
8	Not Used		

7M-GE Gearbox

Harness + Color	Resistance Gearbox	
	Cold	Hot
Gearbox Red	11 - 18	White
Gearbox Yellow	11 - 18	Black
Gearbox Green	3.5 - 4.6	Yellow
Gearbox Blue	Not used	

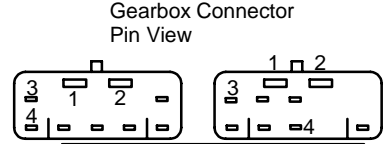

Gear Selector Connector
 Pin 1 & 2 is closed in Park & Neutral for safe starting
 Pin 3 & 4 is closed in reverse

Pin Description Harness

1.	Negative	Blue
2.	Positive	Red

The TPS must be connected to an ECU system which supplies the 5V and ground signal